



NEW HOLLAND

W270_B



| | |
|------------------|--------------------------|
| MAXIMUM POWER | 239 kW - 320 hp |
| OPERATING WEIGHT | 23 170 kg |
| BUCKET CAPACITY | 4.0 - 4.6 m ³ |



W270B SPECIFICATIONS



ENGINE TIER 3A

Maximum power (ISO 14396/ECE R 120-SAE J 1995)239 kW/320 hp
 Net flywheel power (SAE J1349).....221 kW/296 hp
 Rated engine speed2100 rpm
 Make and modelCUMMINS QSM11-C
 Type ...Diesel, 4 Stroke, electronic injection, turbocharged, aftercooled
 Total displacement10.8 l
 N° of cylinders6
 Bore x stroke125 x 147 mm
 Maximum torque at 1000 rpm.....145 daNm
 Lubrication with gear pump.

The engine conforms to European requirements for "low exhaust emission" in accordance with directive 97/68/EC TIER 3A.



ENGINE MULTIPLE WORK MODES

This latest generation CUMMINS TIER 3A engine, electronically controlled, features **multiple work modes**. According to the type of application, the operator can select the following engine power modes:

- **Maximum power**239 kW/320 hp, for very tough conditions
- **Standard power**221 kW/296 hp, for normal loading conditions
- **Economy power**....179 kW/240 hp, for light load & carry applications
- **Automatic power mode:** to automatically match the power curve to the application.

Perfect electronic control to get the best performances in every type of job while contributing to reduce fuel consumption.



ELECTRICAL SYSTEM

Voltage24 V
 Batteries, in series2
 - Total capacity160 Ah
 - Type.....maintenance-free
 Starter motor7.8 kW
 Alternator capacity95 A



TORQUE CONVERTER

Type.....ZF, single stage / single phase
 Torque multiplication ratio2.99 : 1



TRANSMISSION

Type: ZF Power-Shift countershaft design with four forward and three reverse speeds.

Control: single lever electric "fingertip" type.

Forward speeds.....km/h
 18.0
 213.2
 325.8
 437.4
 Reverse speeds
 18.0
 214.1
 325.8
 with 26.5 x 25 L3 tyres

Safety device prevents engine starting in gear

Automatic Transmission Control (A.T.C.): allows the operator to dedicate attention to the work cycle.

The on-board computer automatically finds the right gear in relation to the type of work.

"**HOLD**" function to maintain selected speed with the machine operating on a slope.

"**KICK-DOWN**" function to shift from 2nd to 1st gear when high pushability is required.

"**DOWN-SHIFT**" function to select the most suitable speed with the machine on a slope. Low gears favour the use of the engine brake function and consequently reduce brake use.

Forward and reverse control switch.



AXLES

ZF rigid front axle, oscillating rear axle designed for heavy duty applications.

Rear axle oscillation.....24°

Rear wheel vertical travel480 mm

"Limited Slip" differentials.

Hermetically sealed final drives and wet disc brakes.



BRAKES

Service brakes.....self-adjusting

Typewet disc brakes on all four wheels

Servo-assisted hydraulic brake circuit.

Independent circuit for each axle.

Control pedal located to left of steering column.

Electrical transmission disengagement switch.

The brake circuit complies with the following international standards:

ISO 3450, CEE 71/320, SAE J1473

Parking brake: spring applied hydraulically released caliper disc brake on transmission output shaft.

Electrical control by means of switch in cab.



TYRES

Type.....Tubeless

Radial26.5 R-25 XHA TL

26.5-25 GP-2B

26.5-25 XLDD2

750/65R25XLD



HYDRAULIC SYSTEM

Type.....load sensing circuit, closed centre

Pumps2 - variable displacement -axial pistons

feeding the integrated implement and steering system

Max. flow delivery.....324 l/min

Max. working pressure248 bar

Control valve2 spool

3 spool

Controlpiloted dual lever

piloted, single lever

Double-acting hydraulic cylinders

Booms2

Bore x stroke165 x 870 mm

Bucket.....1

Bore x stroke180 x 745 mm

Operating time

Lift6.2 s

Lower empty.....3.0 s

Dump3.6 s

Hydraulic lines and connecting flanges are equipped with O-ring seals.

L.T.S. device

Load Travel Stabiliser. Invaluable for loading and transport on uneven terrain.

W270B

DIMENSIONS mm

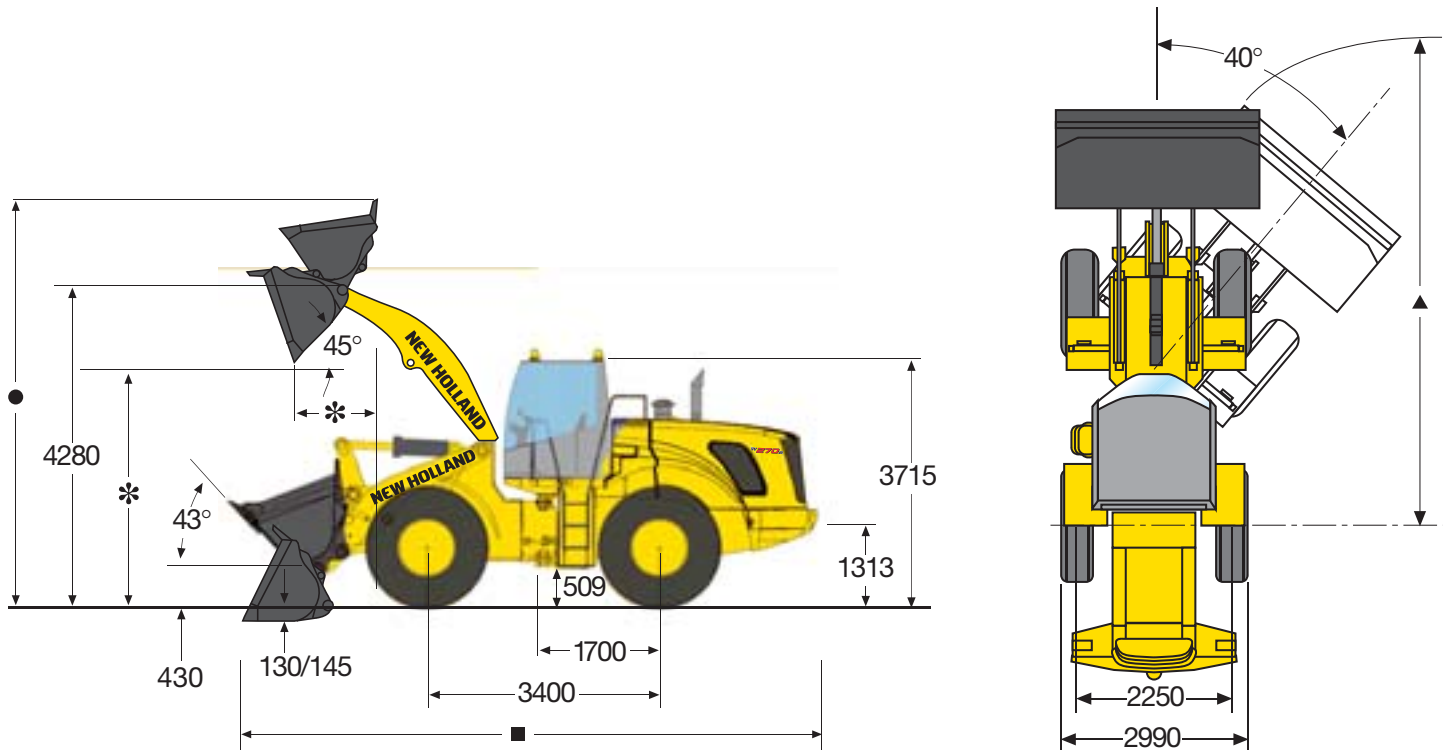

PERFORMANCE

GENERAL PURPOSE

| BUCKET TYPE | | WITH TEETH AND SEGMENTS | | WITH CUTTING EDGE EXTENSION | | WITH TEETH | |
|--|----------------|-------------------------|-------|-----------------------------|-------|------------|-------|
| Bucket capacity | m ³ | 4.1 | 4.5 | 4.1 | 4.6 | 4.0 | 4.4 |
| Bucket weight | kg | 2270 | 2400 | 2145 | 2270 | 2090 | 2220 |
| Bucket width | mm | 3045 | 3200 | 3020 | 3070 | 3045 | 3200 |
| Dump height at 45° * | mm | 3015 | 2970 | 3110 | 3070 | 3015 | 2970 |
| Reach at 45° * | mm | 1340 | 1365 | 1265 | 1285 | 1340 | 1365 |
| Overall length (bucket on ground) ■ | mm | 8895 | 8955 | 8760 | 8815 | 8895 | 8955 |
| Overall height (bucket raised) ● | mm | 5833 | 5895 | 5833 | 5895 | 5833 | 5895 |
| Turning radius ▲ (bucket at carry position) | m | 6.8 | 6.9 | 6.8 | 6.8 | 6.8 | 6.9 |
| Breakout force | daN | 20600 | 19800 | 19700 | 19100 | 22700 | 21500 |
| Static tipping load: 0° | kg | 19350 | 19300 | 19450 | 19370 | 19500 | 19400 |
| 40° | kg | 16760 | 16700 | 16870 | 16800 | 16900 | 16850 |
| Max operating weight | kg | 23470 | 23560 | 23370 | 23480 | 23280 | 23380 |

* At bucket cutting edge

| TIPPING LOAD AND WEIGHT VARIATIONS | | WEIGHT | TIPPING LOAD 0° | 40° |
|------------------------------------|----|--------|--------------------|------|
| 26.5-25 L4 | kg | +501 | +48 | +30 |
| 26.5-25 L5 | kg | +695 | +205 | +169 |

Note: All performance data and specifications based on a unit with 26.5R25XHATL radial tyres, ROPS cab, full fuel and operator. All data is obtained in compliance with the latest applicable SAE Recommended Practices including J732c, J742b and ISO 6746/1, ISO 6746/2 and ISO 8313.

W270B

PERFORMANCE “LONG BOOM”

GENERAL PURPOSE

| BUCKET TYPE | | WITH CUTTING EDGE EXTENSION |
|-----------------------------------|----------------|-----------------------------|
| Bucket capacity | m ³ | 4.1 |
| Bucket weight | kg | 2145 |
| Bucket width | mm | 3020 |
| Dump height at 45° | mm | 3110 |
| Reach at 45° (at 2130 mm height) | mm | 1900 |
| Overall length (bucket on ground) | mm | 8755 |
| Overall height (bucket raised) | mm | 5835 |
| Turning radius (at bucket edge) | m | 6.78 |
| Breakout force | kg | 20775 |
| Static tipping load: | kg | |
| 0° | | 19600 |
| 40° | | 16870 |
| Operating weight | kg | 22920 |



BUCKET SELECTIONS

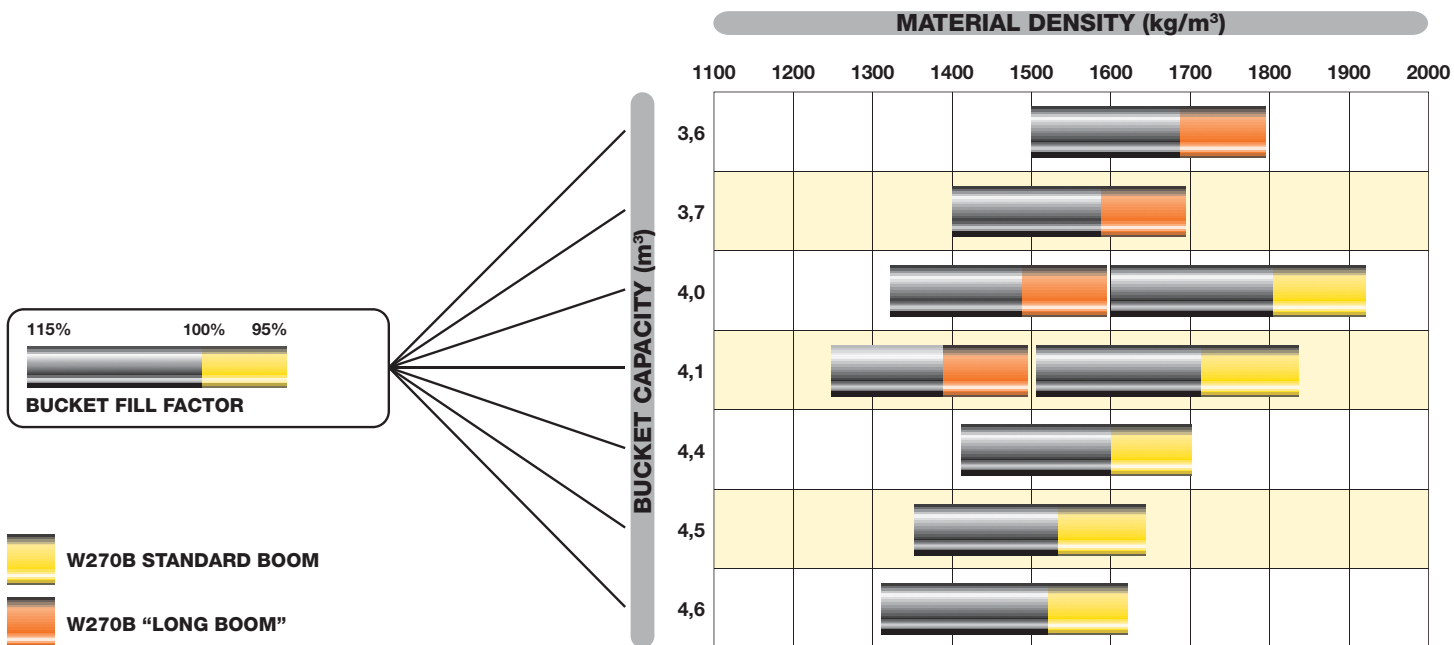



STEERING

Type**Orbitrol**, hydraulically actuated with priority valve
 Pump.....utilises one of the hydraulic pumps
 Max. flow rate162 l/min
 Max. working pressure248 bar
 Cylinders2, double acting
 Bore x stroke89 x 477 mm
 Emergency steering circuit with electric engine activated by onboard computer.



CAB

ROPS/FOPS modular cab.

Excellent, all-round, visibility.

The ROPS/FOPS cab complies with the following standards:

ROPS - EN 13510

FOPS - EN ISO 3449



CAPACITIES

| | Litres |
|------------------------|--------|
| Lube oil | 37 |
| Coolant | 57 |
| Fuel tank | 394 |
| TRANSMISSION | |
| Hydraulic system | 242 |
| AXLES:front/rear..... | 47/53 |



NEW HOLLAND. THE POWER OF A GLOBAL BRAND

New Holland is a global brand with a key position in the Construction Equipment business. It supplies a **complete range of 13 product lines and 80 basic models** split into **Compact line** and **Heavy line**. It operates in all the main markets, such as **Europe, North and Latin America, Africa, Asia and Middle East** with the same technology and under the same logo and brand. It manufactures **durable, safe and productive** machines aimed at supporting customers in developing their own business. **Dealers are company partners**. They play an important role to support the brand in their territories through intense professional relationship with Customers. New Holland is reinforced by its **global alliance with Kobelco**: world leader in hydraulic excavator technology.



AT YOUR OWN DEALERSHIP

The information contained in this brochure is intended to be a general nature only. The NEW HOLLAND KOBELCO CONSTRUCTION MACHINERY S.p.A. company may at any time and from time to time, for technical or other necessary reasons, modify any of the details or specifications of the product described in this brochure. Illustrations do not necessarily show products in standard conditions. The dimensions, weights and capacities shown herein, as well as any conversion data used, are approximate only and are subject to variations within normal manufacturing techniques.

Published by NEW HOLLAND KOBELCO CONSTRUCTION MACHINERY S.p.A.
Printed in Italy - LEADER Firenze - Cod. 30 342GB - Printed 04/09

Printed on recycled paper
CoC-FSC 000010 CQ Mixed sources



ELEMENTAL
CHLORINE
FREE
GUARANTEED

FIAT
GROUP



BUILT AROUND YOU



www.newholland.com